

FORTIS™ MAGLOCK INSTALLATION INSTRUCTIONS

Instructions For Magnetic Locking Devices

Important: Please Read Before Attempting To Install Magnetic Lock

- A. Handle the equipment with care, damaging the mating surfaces of the magnet or armature plate may reduce locking efficiency.
- B. The magnet mounts rigidly to the door frame, The armature plate mounts to the door with hardware. Kit provided that allows it to pivot about its center to compensate for door wear and misalignment.
- C. Template use must take place with the door in its normally closed position.
- D. Firmly tighten all screws.

Typical Installation:

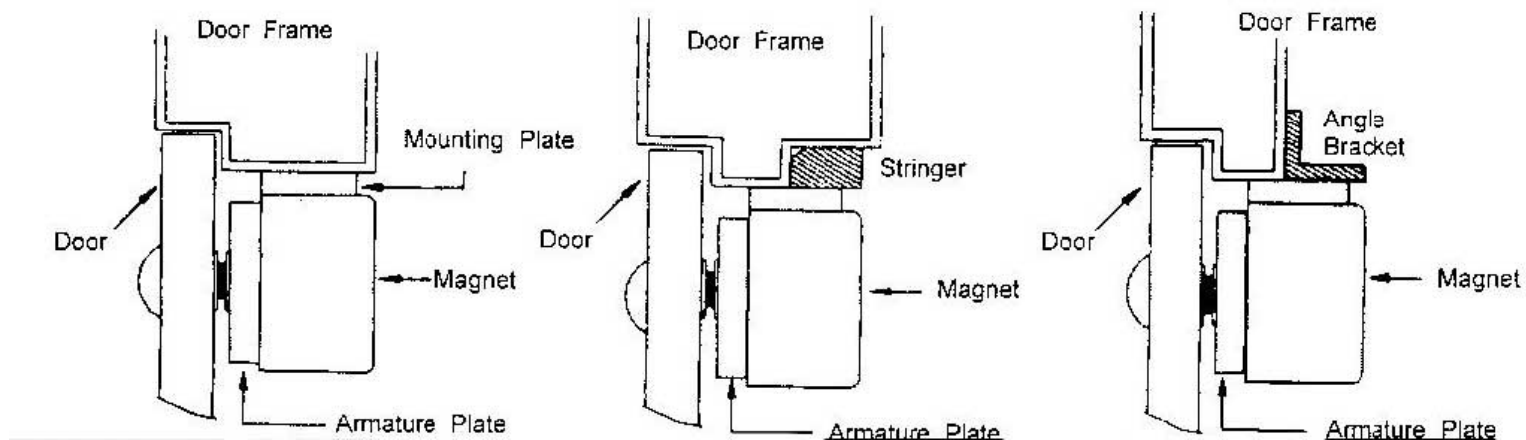

Fortis Security Products™
 PO Box 1902, Westville, 3630
 TEL: 0800 204 563

Armature Plate Mounts To The Door

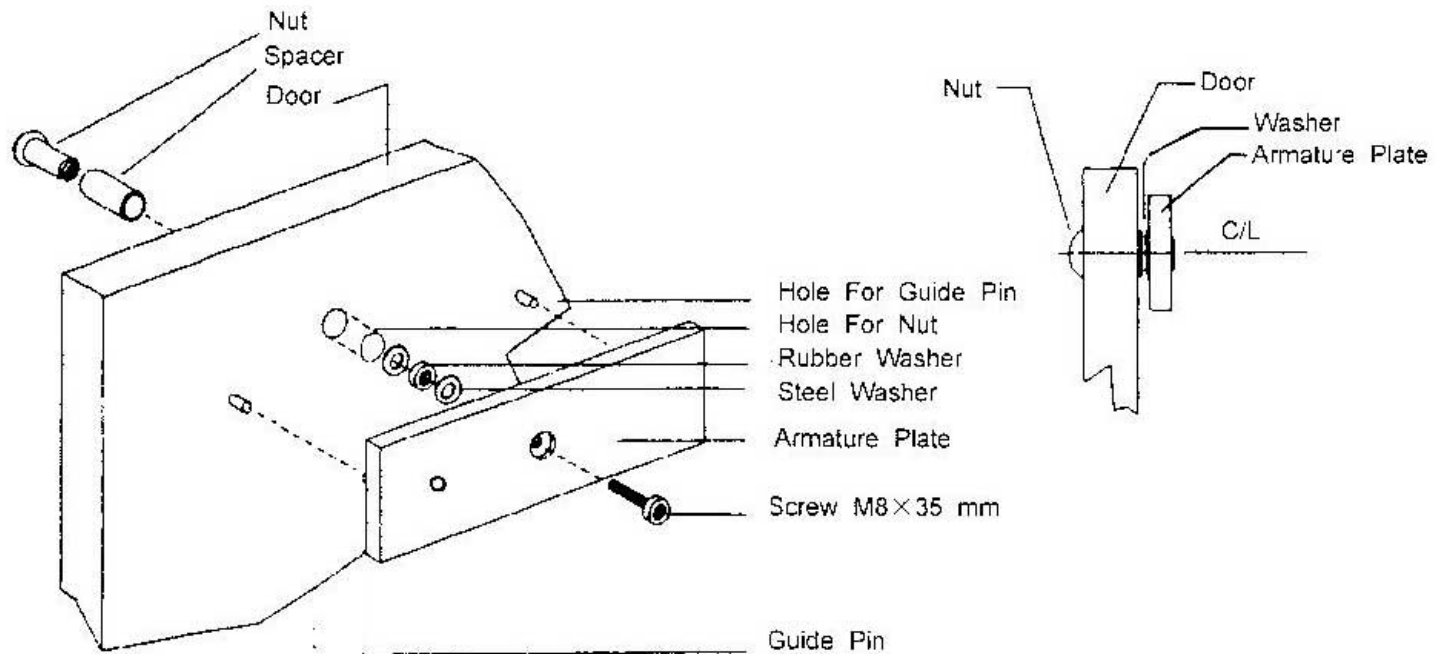

****Important:** Fix the armature plate not too tightly, and make the rubber washer more flexible, in order to make the armature plate automatically adjust its proper position with the magnet.



Fortis Security Products™
 PO Box 1902, Westville, 3630
 TEL: 0800 204 563

Installation Guide

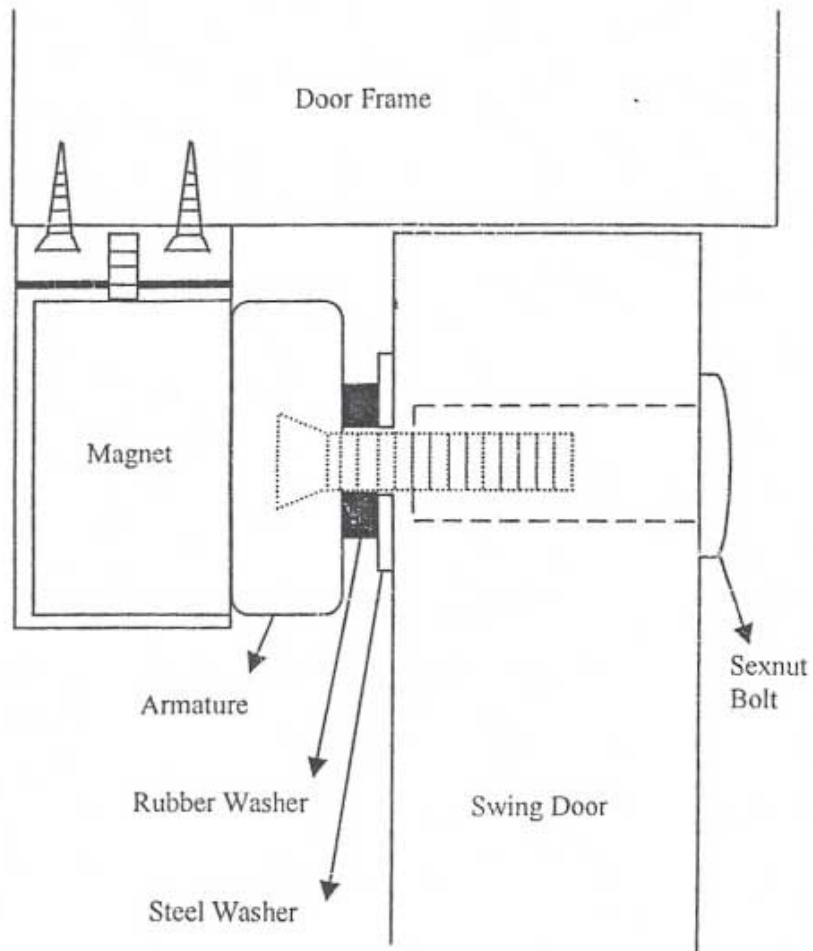

Wiring Guide

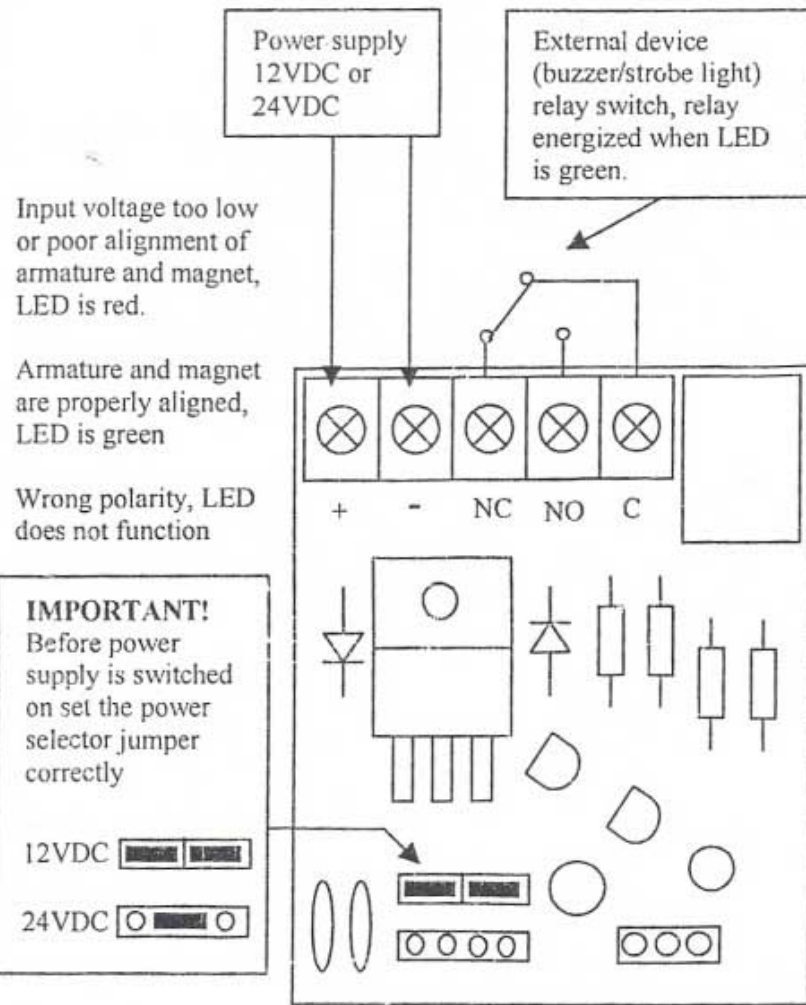

Fortis Security Products™
 PO Box 1902, Westville, 3630
 TEL: 0800 204 563

INSTALLATION OF ADJUSTABLE L BRACKET

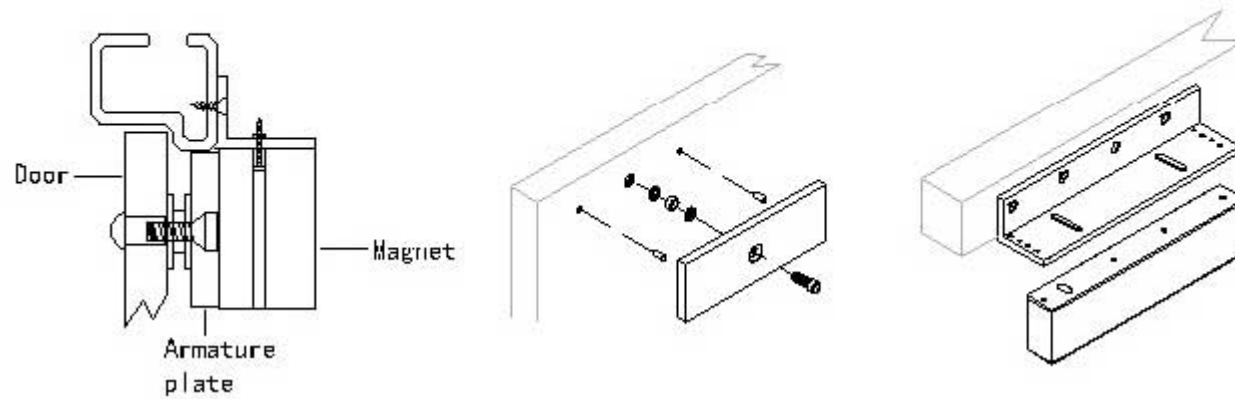

INSTALLATION OF L&Z BRACKET (ADJUSTABLE)

